

1	2	3	4	5
No.	NAME	MATERIAL	DWG/MATL No.	CODE
				Q'TY
				0
				SIZE
				WEIGHT
				REMARK

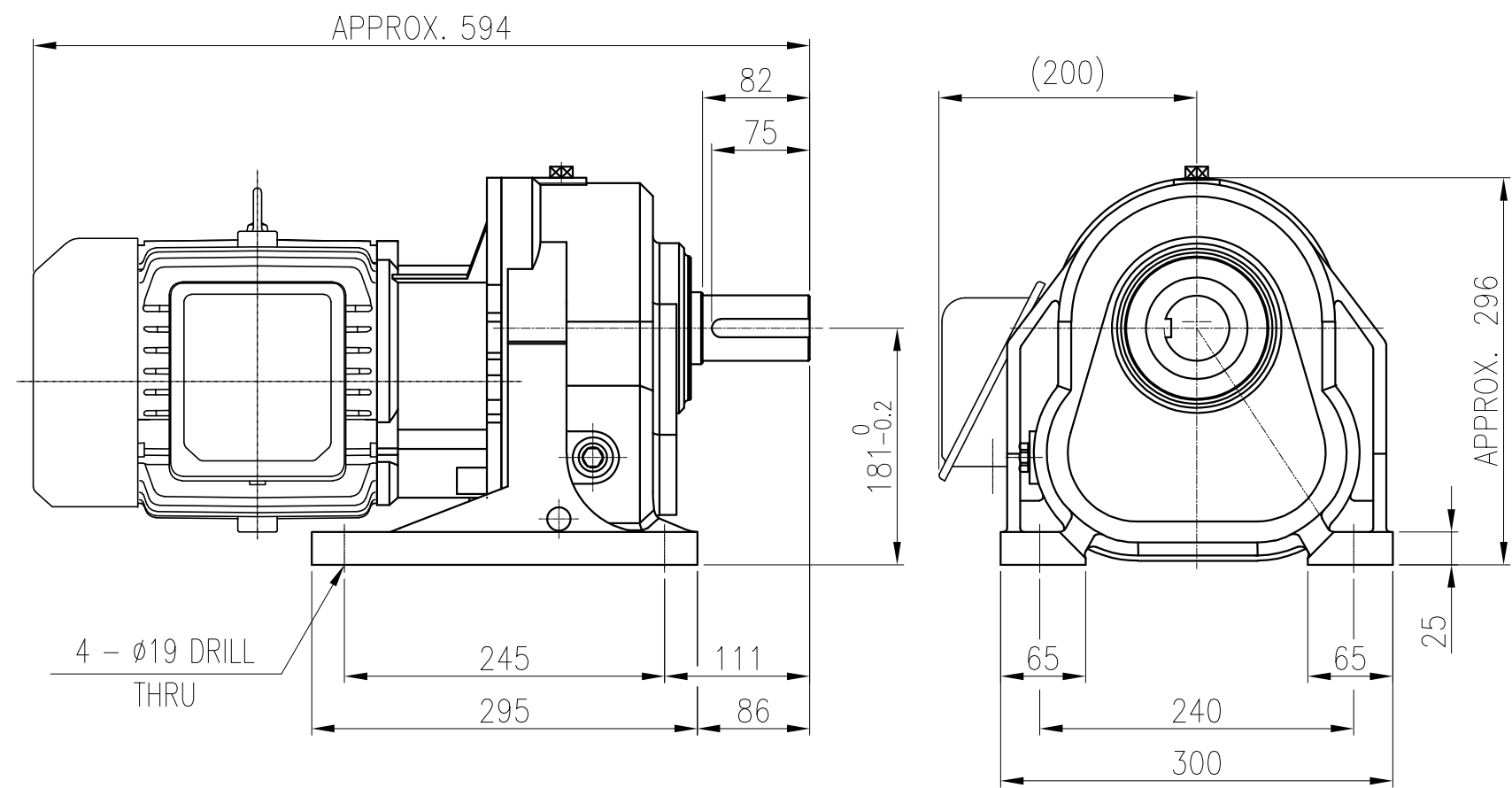
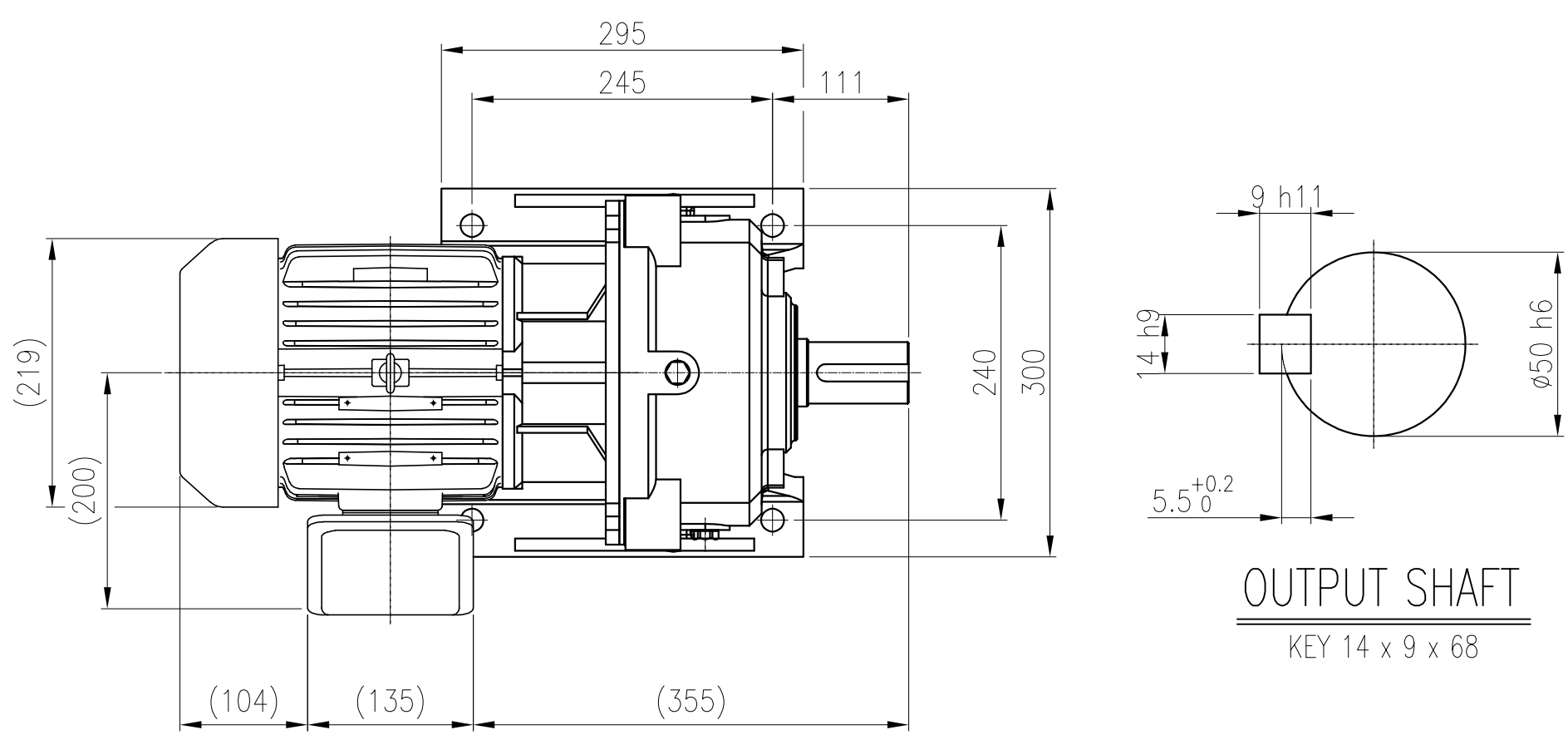

		BEARING			
OIL SEAL		2ND PINION	6204ZZ	6203ZZ	GREASE : NLGI(EP)00
MOTOR SHAFT	D(M) 35 x 47 x 7	3RD PINION	6206ZZ	6307ZZ	ABOUT 0.86 kg
OUTPUT SHAFT	D(M) 55 x 78 x 12	OUTPUT SHAFT	PM3530	22211	WEIGHT 90.51 kg

		외형도 OUTLINE DIMENSION			
		DWG No. EK2D007669H001		UNIT	mm
				SCALE	1:1
No.	DATE	DESIGNED	CHECKED	REVIEWED	APPROVED
		2019.01.21	2019.01.21	2019.01.21	2019.01.21
		하슬기	문병선	박희성	홍원철
		DATE			2019-01-21
		REVISION No.			00
		THIRD ANGLE PROJECTION			
TYPE 18Fr(2.2W)_40~100:1_프리미엄		REF. No.			-
					(A)

이 도면에 표시된 정보는 호성중공업(주)의 소유이며 당사의 사전 서면동의 없이 무단사용을 금합니다.